

Potentiometers

Showcase your project!

week 05



Sensor 2: Photocells and Force Sensors

Analog input and Processing

Photocell



Photocell

Force Sensitive Resistor



Force Sensitive Resistor

Photocell



\$0.01



Photocell

Force Sensitive Resistor



\$5.50



Force Sensitive Resistor

Potentiometers

- Variable resistor (a type of “resistive sensor”)
- Pot for short
- When you need a “ranged” input
- Measures rotational position (knob for volume, light dimmer, etc.)

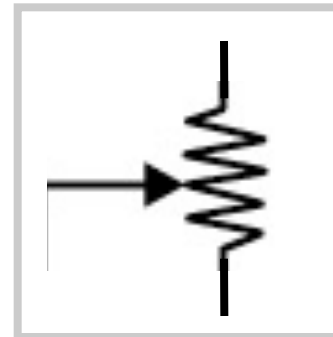

pot

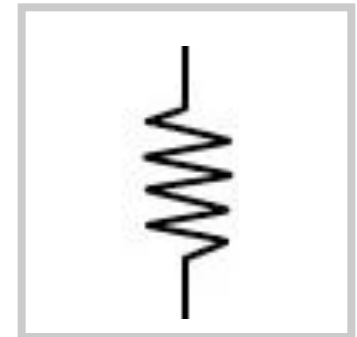

resistor

Potentiometers

- It's like a faucet (if current is analog to water flow)
- Like any other resistor, but you can vary the amount of resistance
- Generally used for making a varying voltage (remember, Arduino measures voltage differences, not resistance differences)

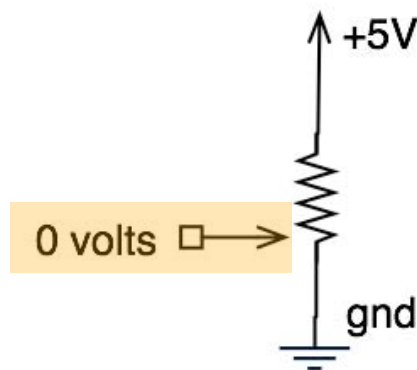

**turned
anti-
clockwise**

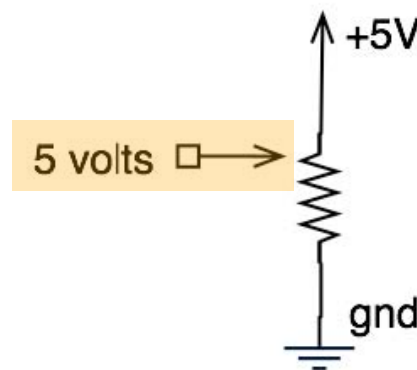

**turned
clockwise**

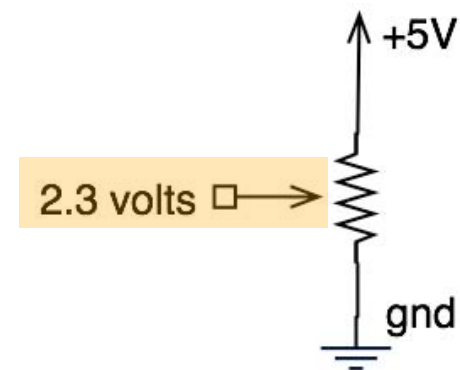

**somewhere
in the middle**

Voltage Divider

Potentiometer is a type of voltage divider.

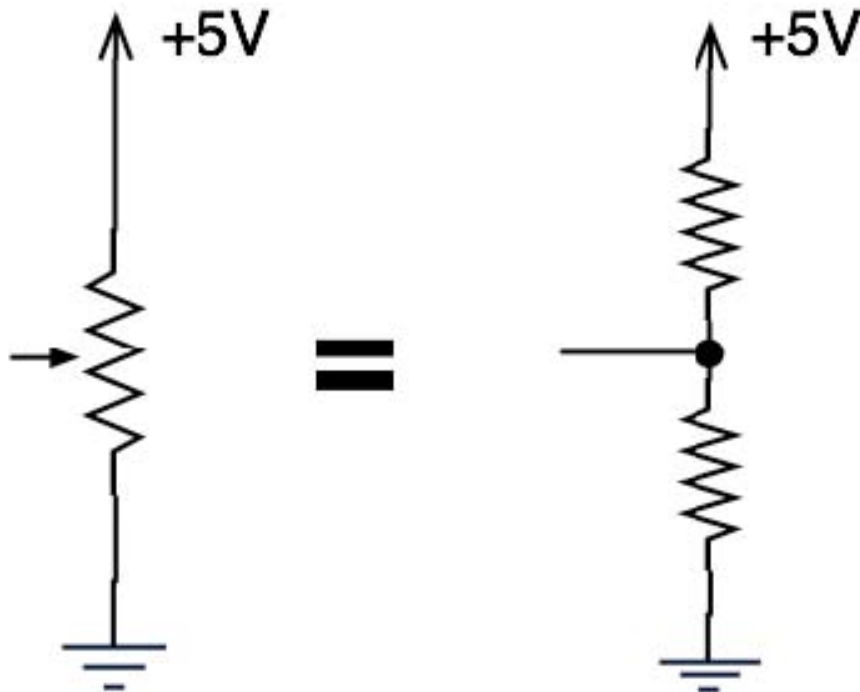

Photocells (aka photoresistor)

Brighter light == lower resistance

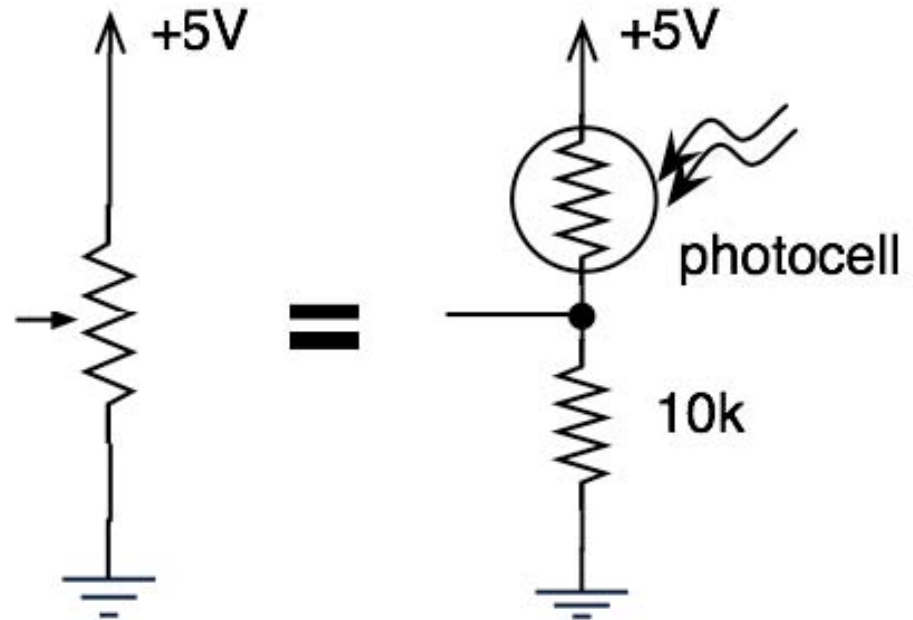

Force Sensitive Resistors

More pressure == lower resistance

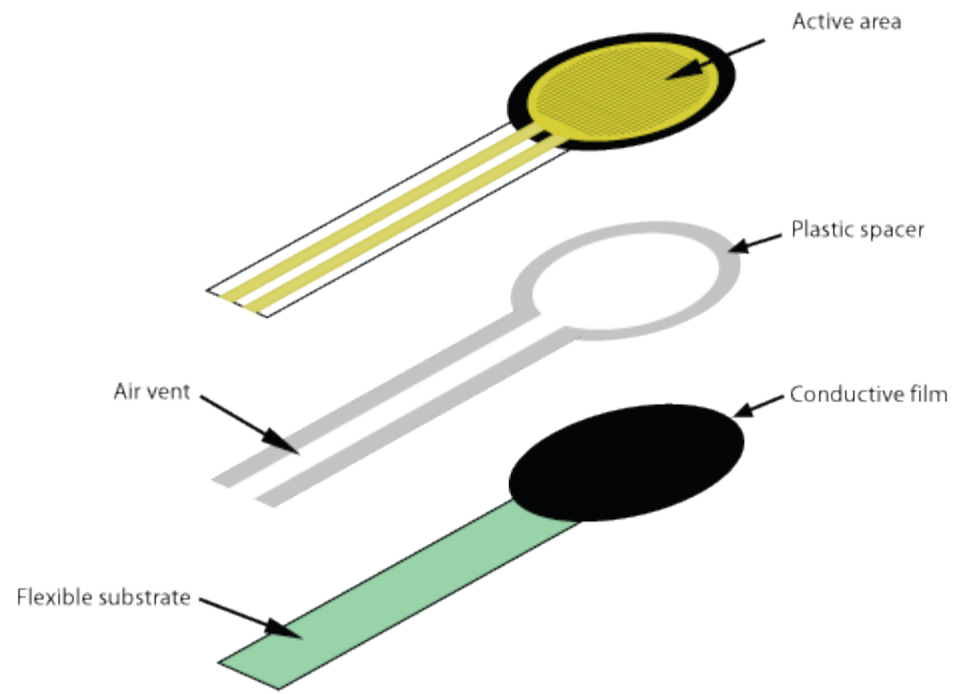

Force Sensitive Resistors

Experiment with different pressure objects, sponge, plates, etc.

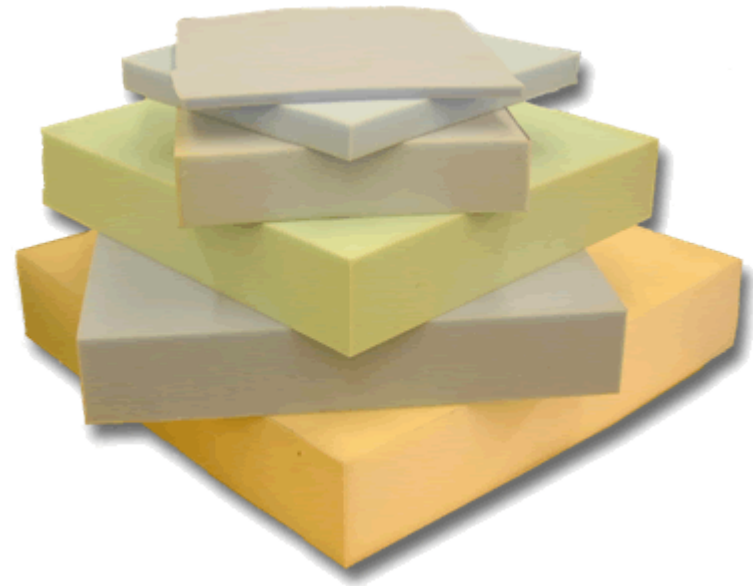

Working with Processing

Arduino as an interface board

Arduino to Computer

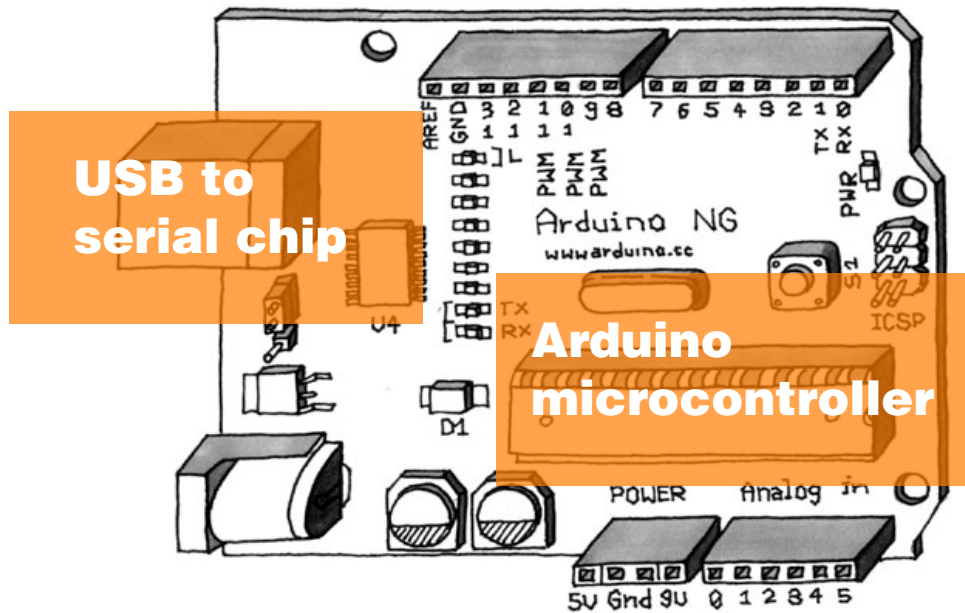

Arduino to Computer

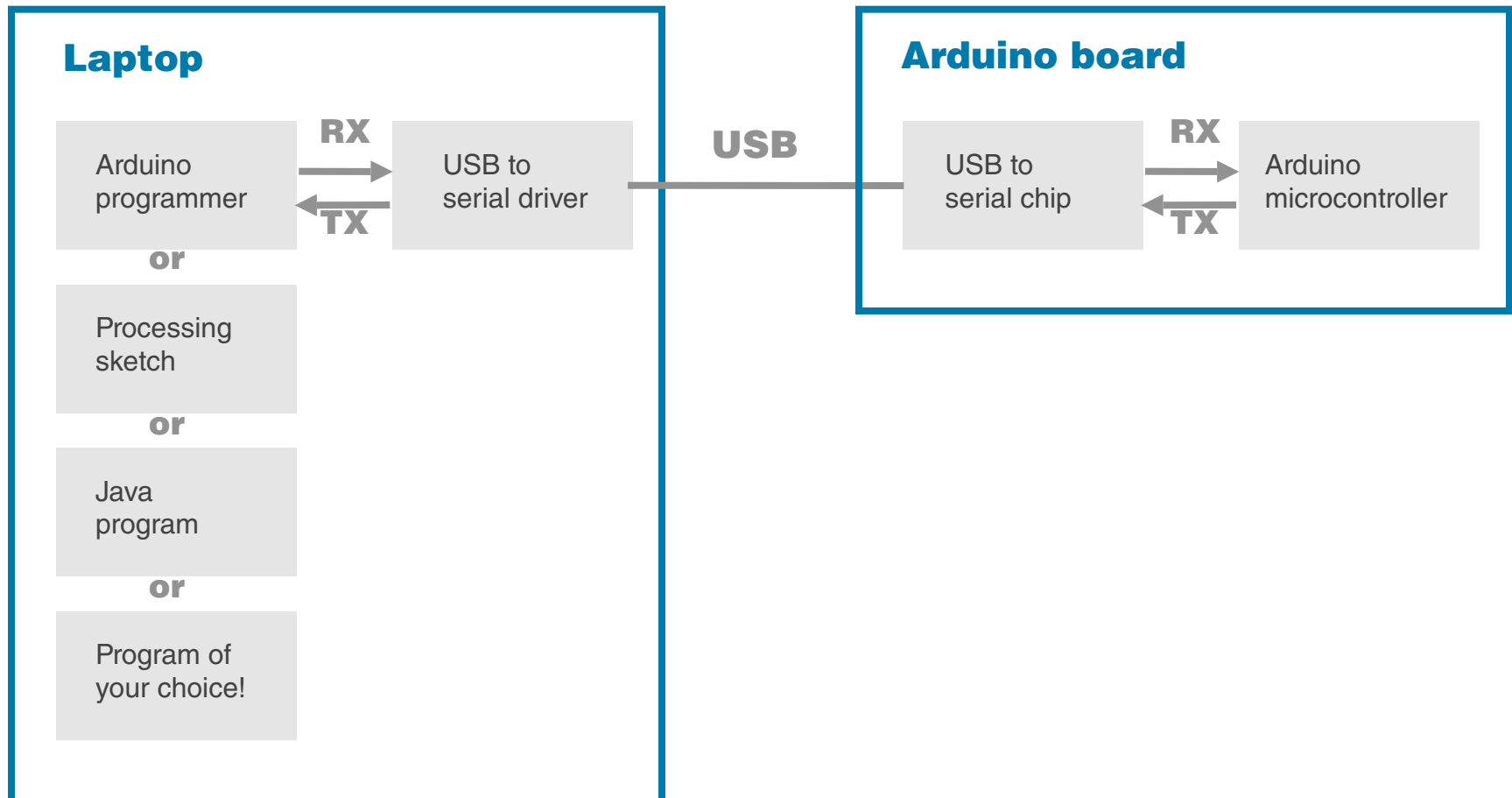

Processing

Open source programming language and environment for images, animation, and interactions.

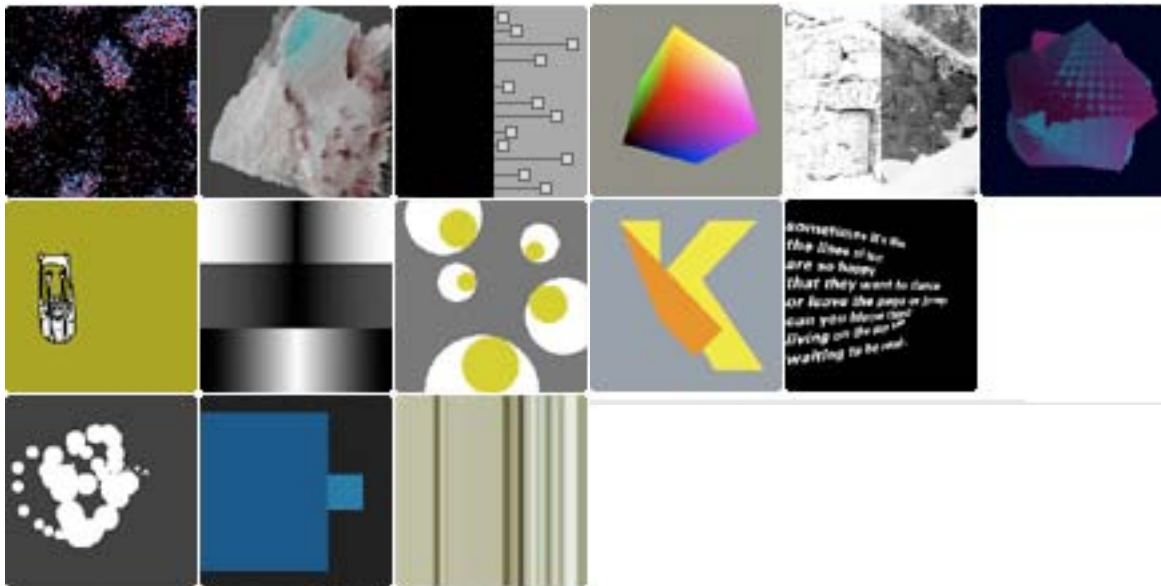

Processing

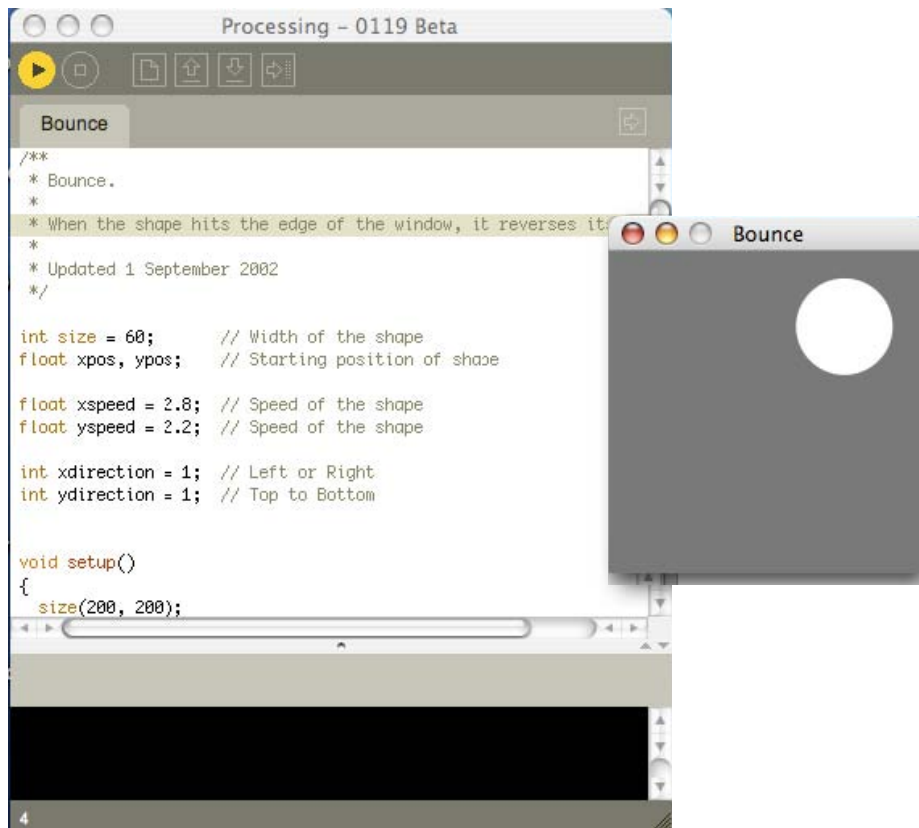

Processing and Serial

Processing has a “Serial” library to talk to Arduino.

1. load library
2. set portname
3. open port
4. read/write port

```
import processing.serial.*;

// Change this to the portname your Arduino board
String portname = "/dev/tty.usbserial-A3000Xv0"; // or "COM5"

void setup() {
  port = new Serial(this, portname, 9600);
}

void draw() {
  // draw something
}

// called whenever serial data arrives
void serialEvent(Serial p) {
  char c = port.readChar();
  if( c == '!' ) {
    // do something
  }
}
```

In Class Exercise

Photocell and LED

SinglePotControlsBrightness.txt

SinglePotControlsBlinking.txt

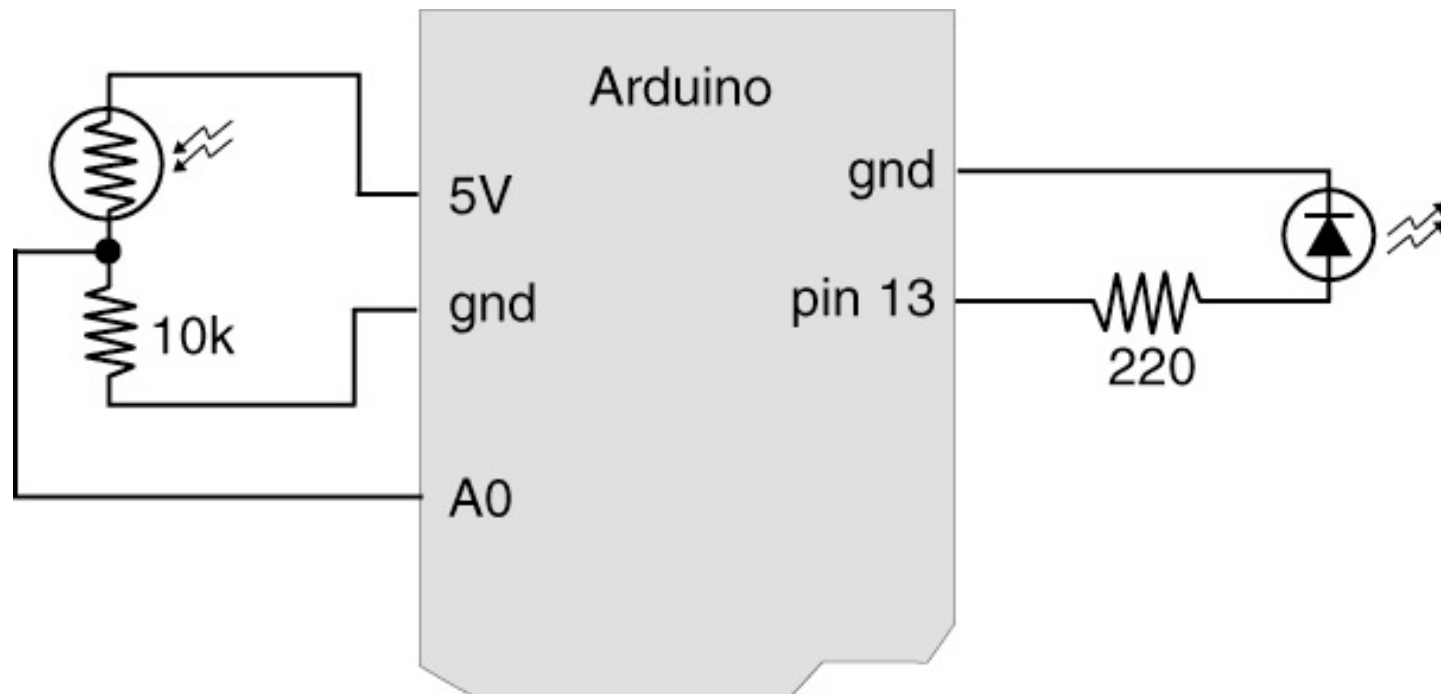

FSR and LED

SinglePotControlsBrightness.txt

SinglePotControlsBlinking.txt

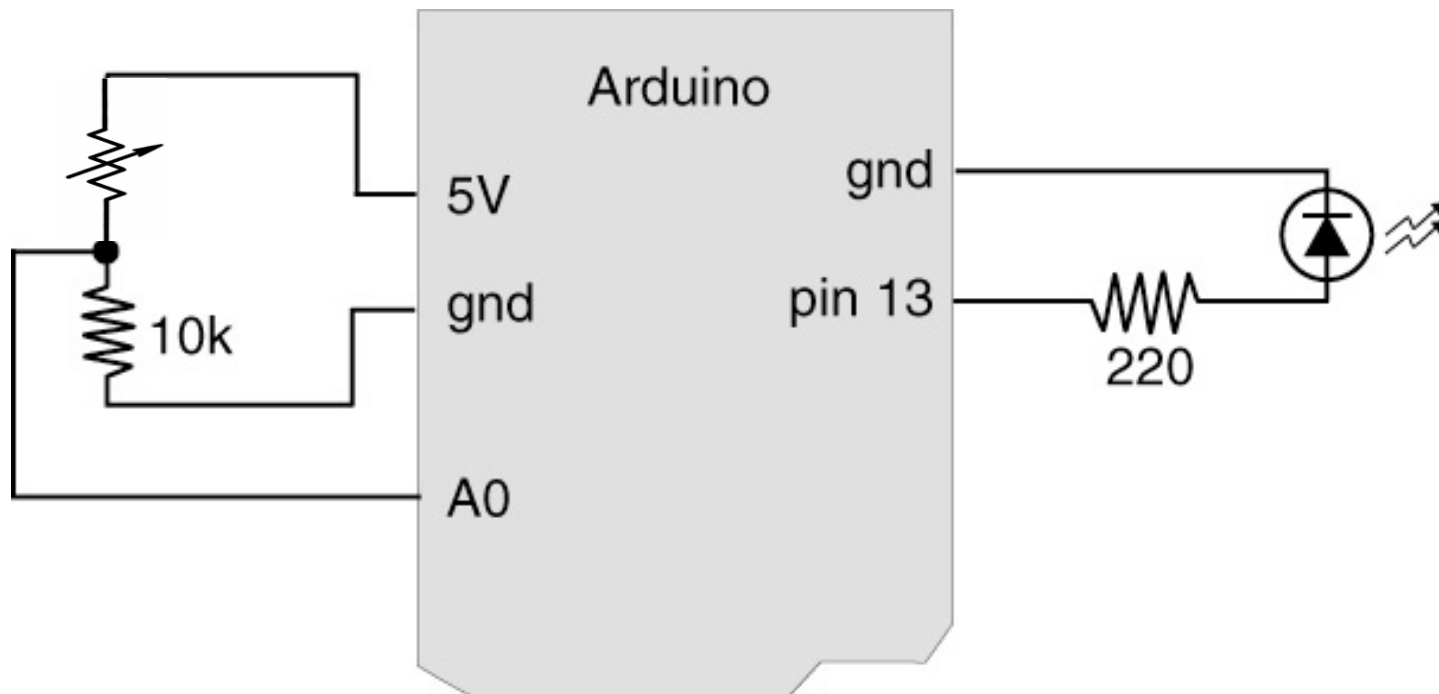

Processing

Download and install Processing from processing.org

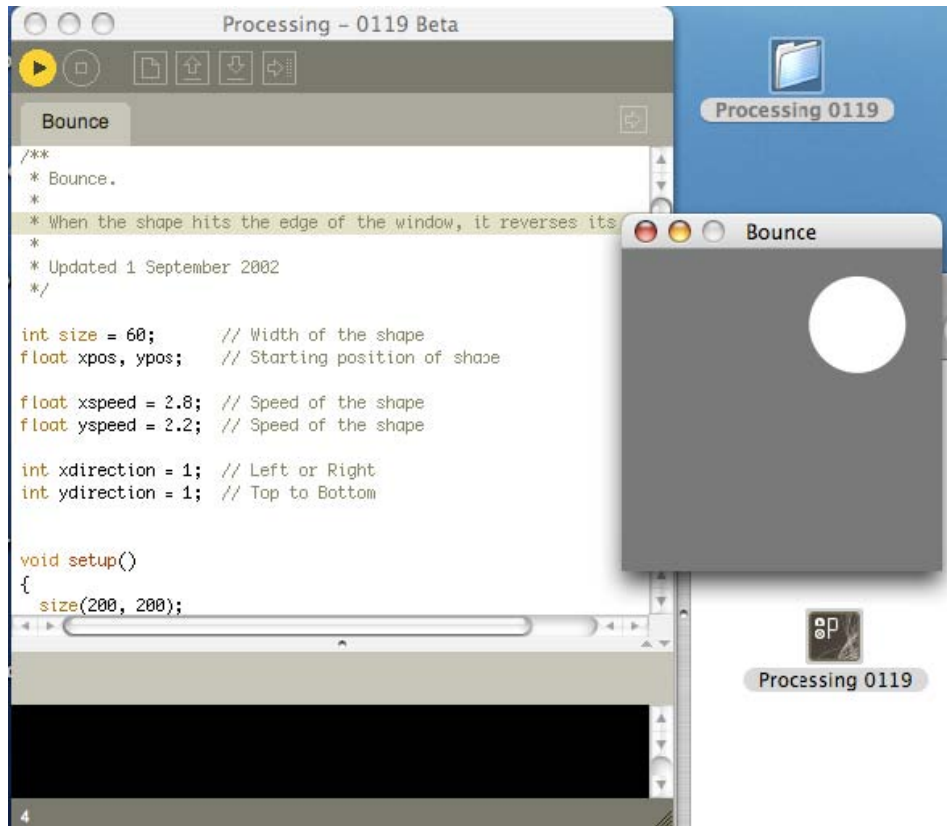

Processing and Arduino

arduino_ball_paint

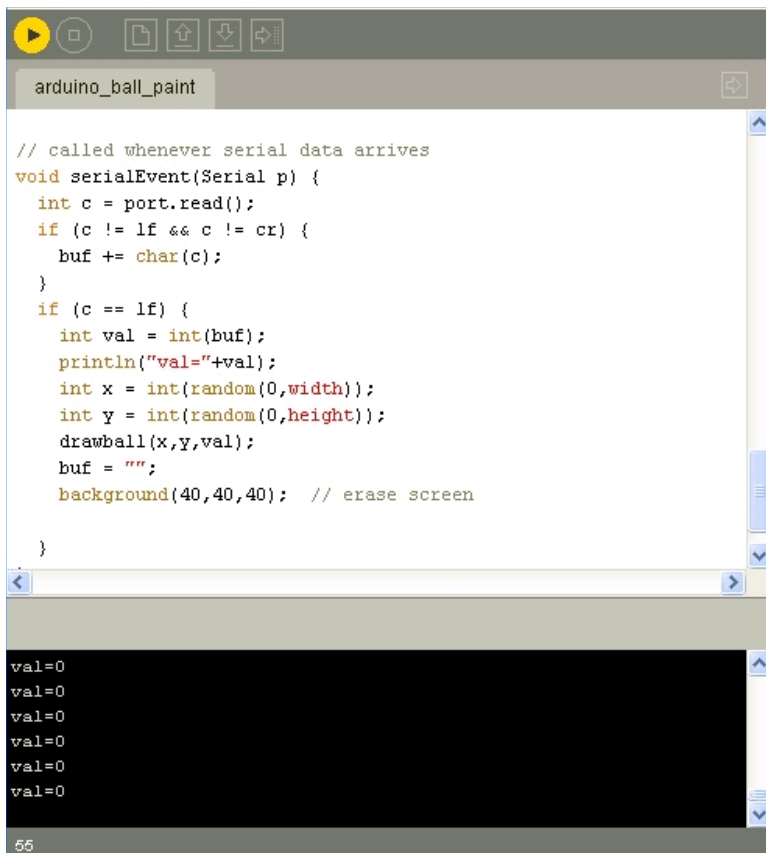

```
// called whenever serial data arrives
void serialEvent(Serial p) {
  int c = port.read();
  if (c != lf && c != cr) {
    buf += char(c);
  }
  if (c == lf) {
    int val = int(buf);
    println("val="+val);
    int x = int(random(0,width));
    int y = int(random(0,height));
    drawball(x,y,val);
    buf = "";
    background(40,40,40); // erase screen
  }
}
```

```
val=0
val=0
val=0
val=0
val=0
val=0
```



Every time a number is received via the serial port, it draws a ball that size.

Assignment this week

Programming

Create an interesting visualization on your computer that could be influenced by the input from the sensors you have (pot, photocell, FSR, or combination of them). You can use Processing (or any other language you like) in writing the program. Post your results on the course website.

Mechanical

Create a mechanical construction for your FSR that distributes or focuses physical force that is applied. Think about everyday objects (toothpaste tube, entrance mat, paintbrush, pipette, etc.) and how you measure the pressure or force applied to them.

Supplement Readings

Force sensitive resistors: Chapter 11 of Physical Computing

Voltage divider: Chapter 6, pp. 102-108 of Physical Computing

Photocell and LED

SinglePotControlsBrightness.txt

SinglePotControlsBlinking.txt

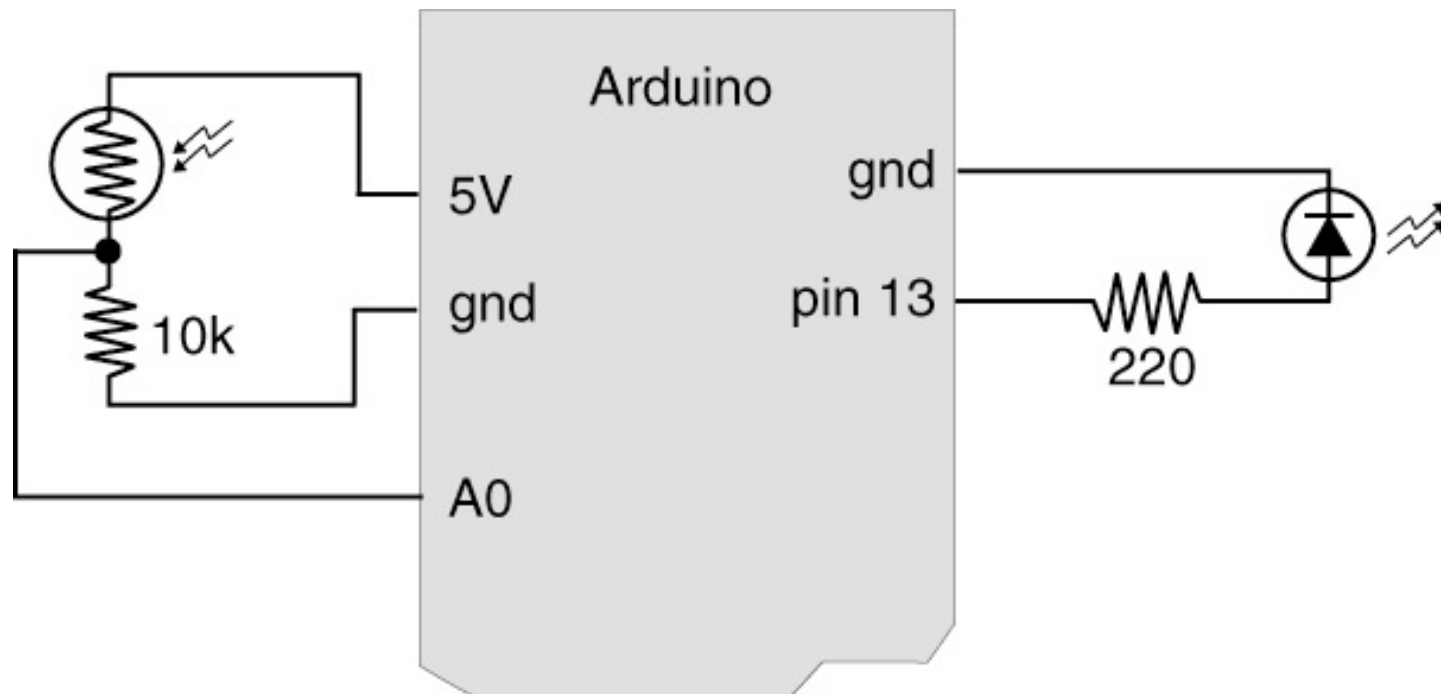

LumiTouch

[Chang, Resner et al., 2001]

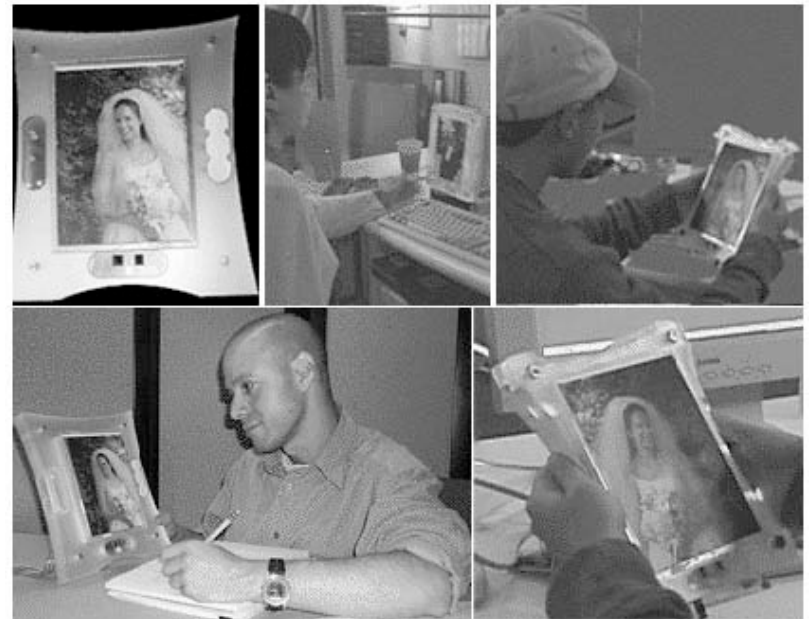

Homework

Programming

Create an interesting visualization on your computer that could be influenced by the input from the sensors you have (pot, photocell, FSR, or combination of them). You can use Processing (or any other language you like) in writing the program. Post your results on the course website.

Mechanical

Create a mechanical construction for your FSR that distributes or focuses physical force that is applied. Think about everyday objects (toothpaste tube, entrance mat, paintbrush, pipette, etc.) and how you measure the pressure or force applied to them.

Thanks!
