

# week 07



## Output 2: DC Motors

---

Making motions

# DC Motor

---

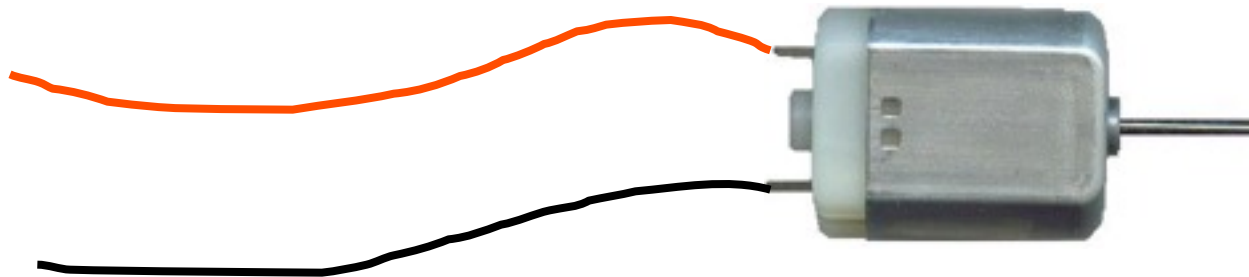

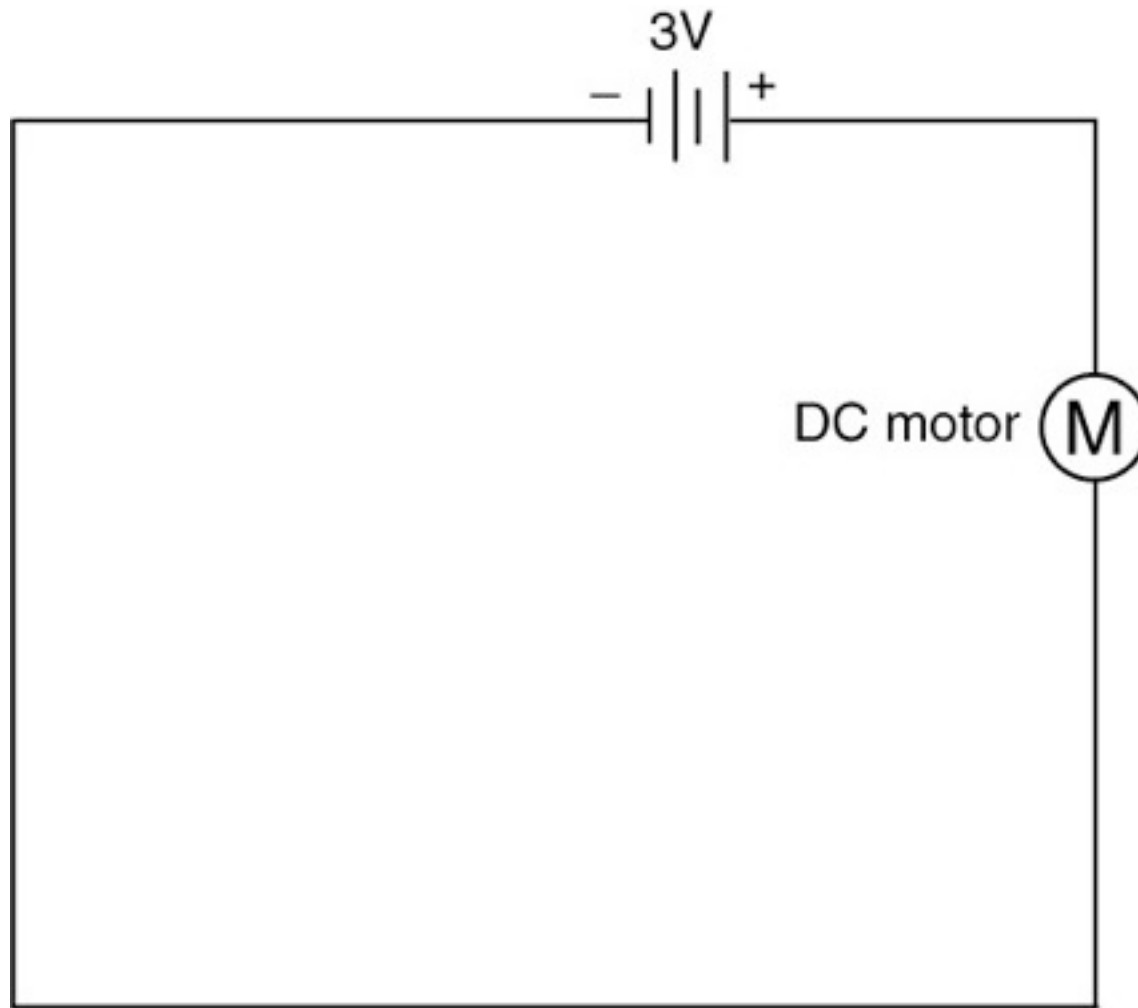

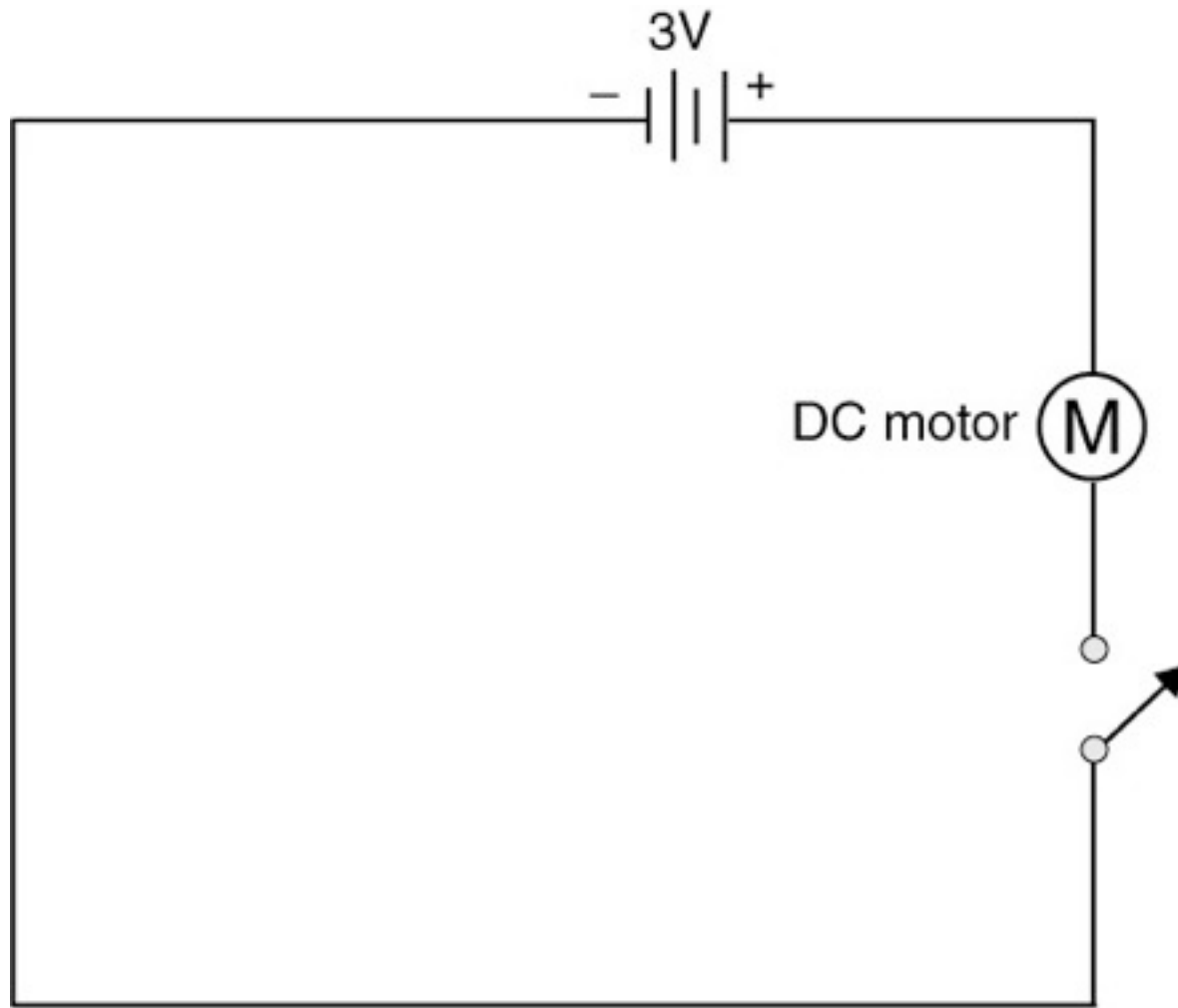

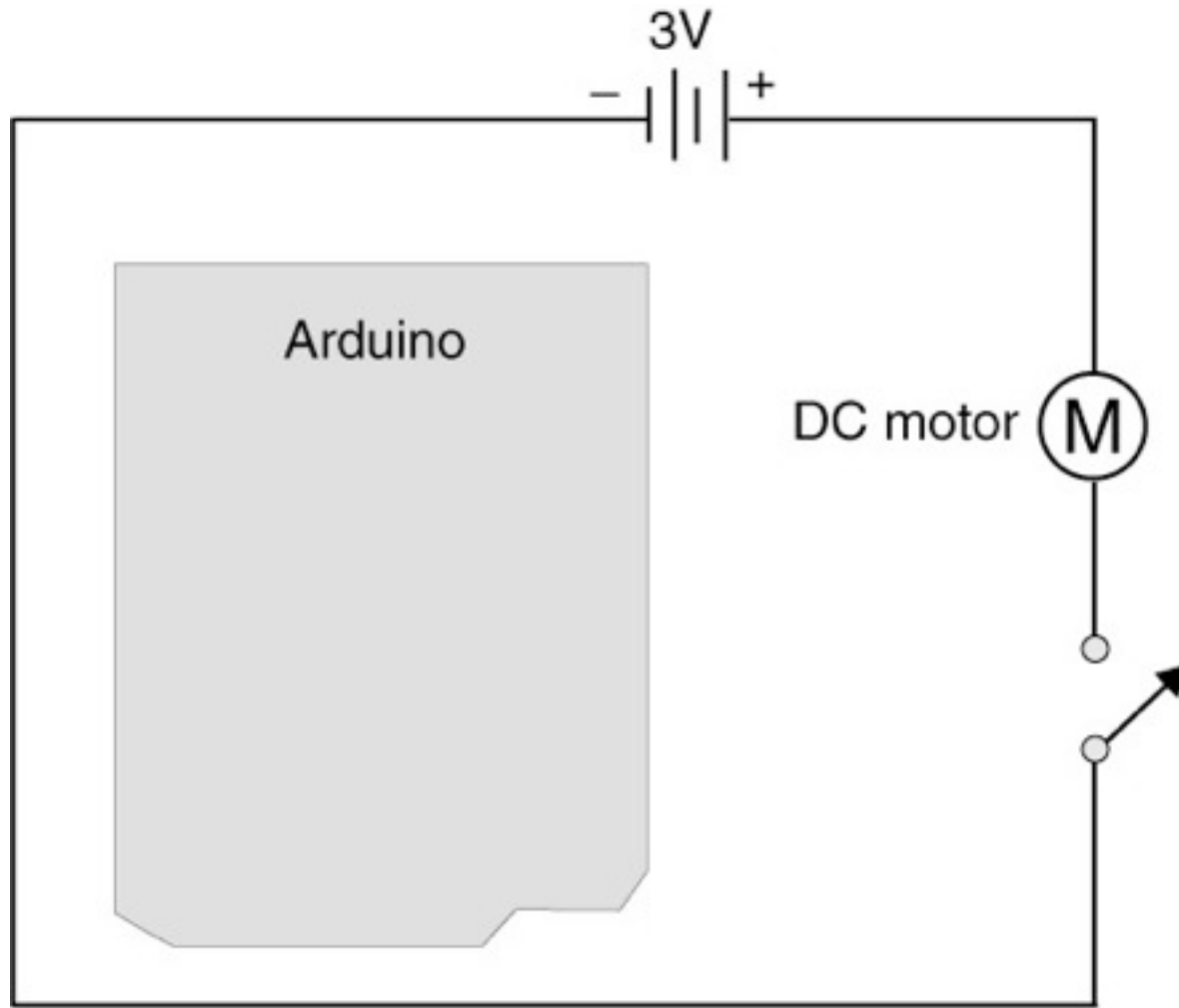

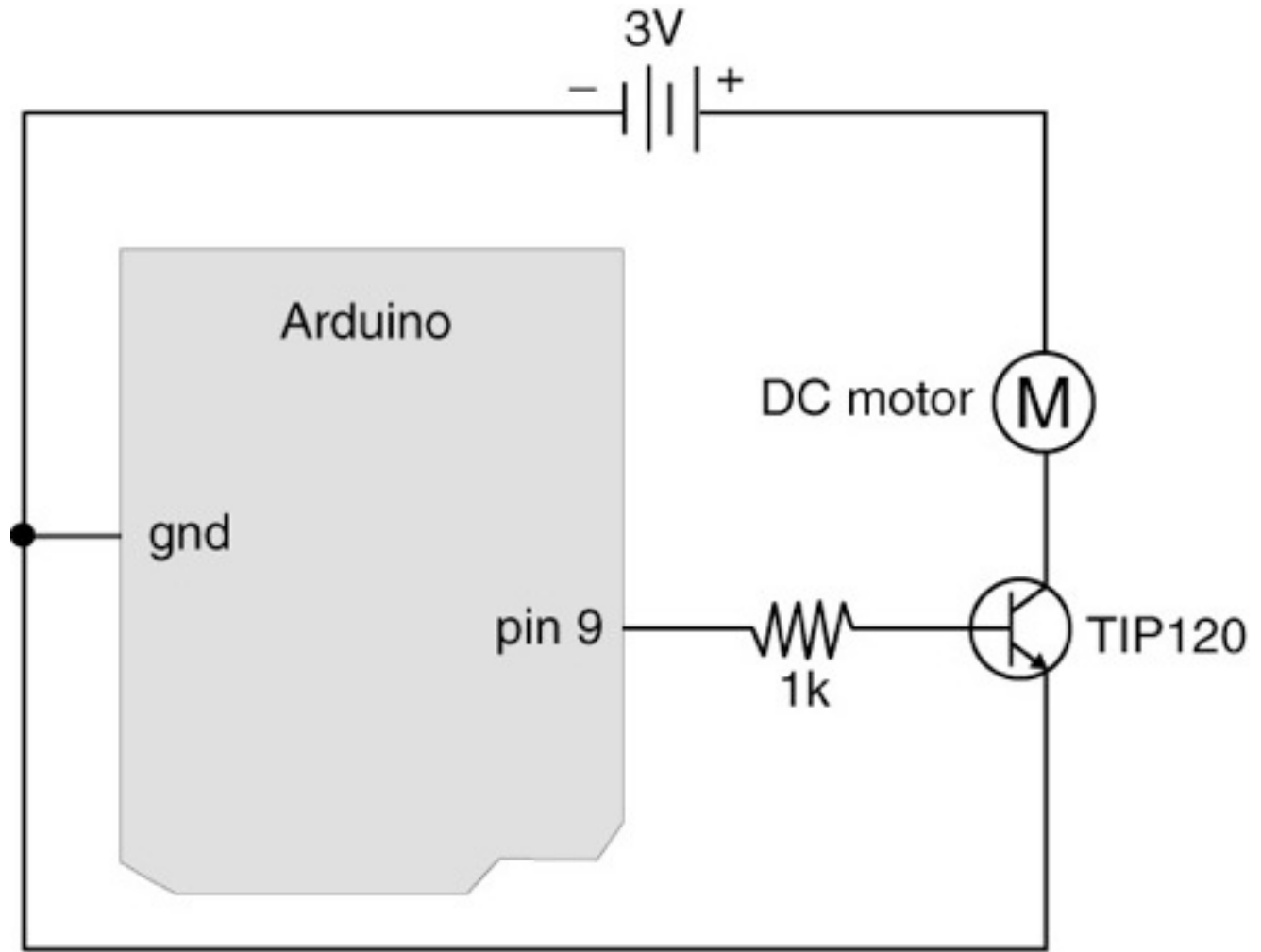

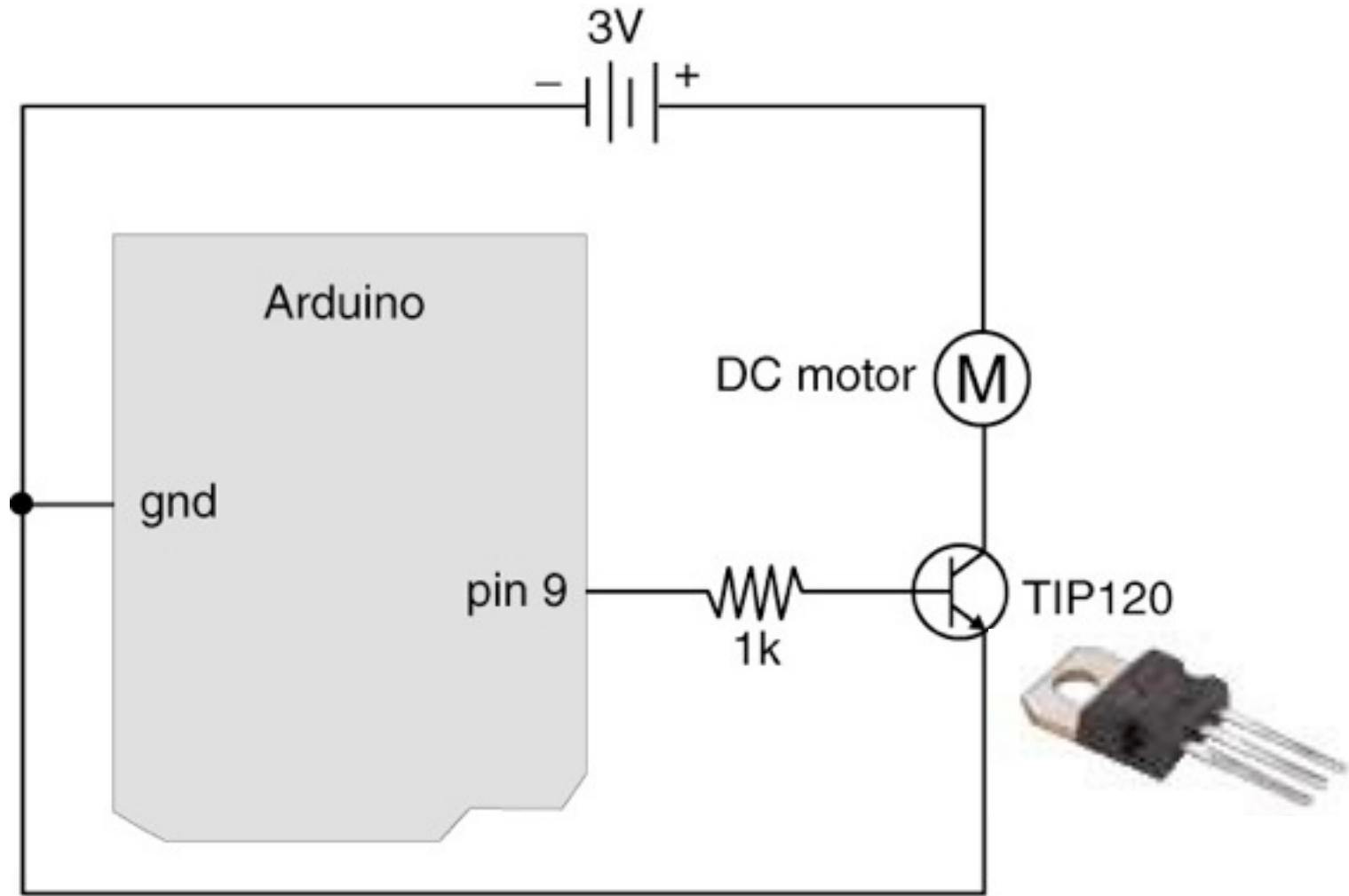

# Transistor

---

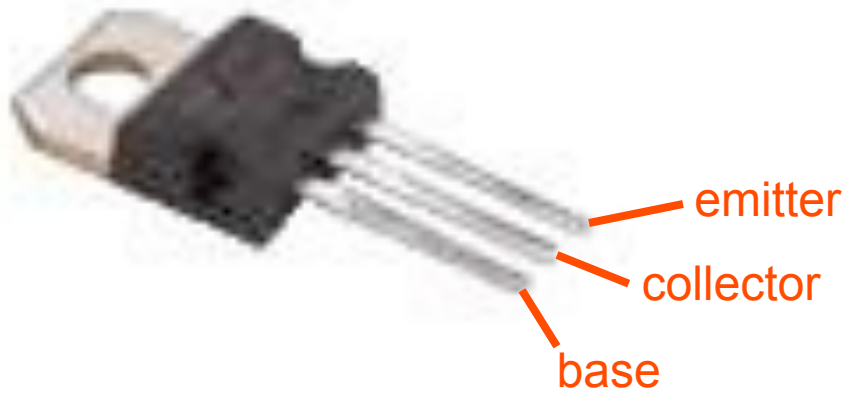



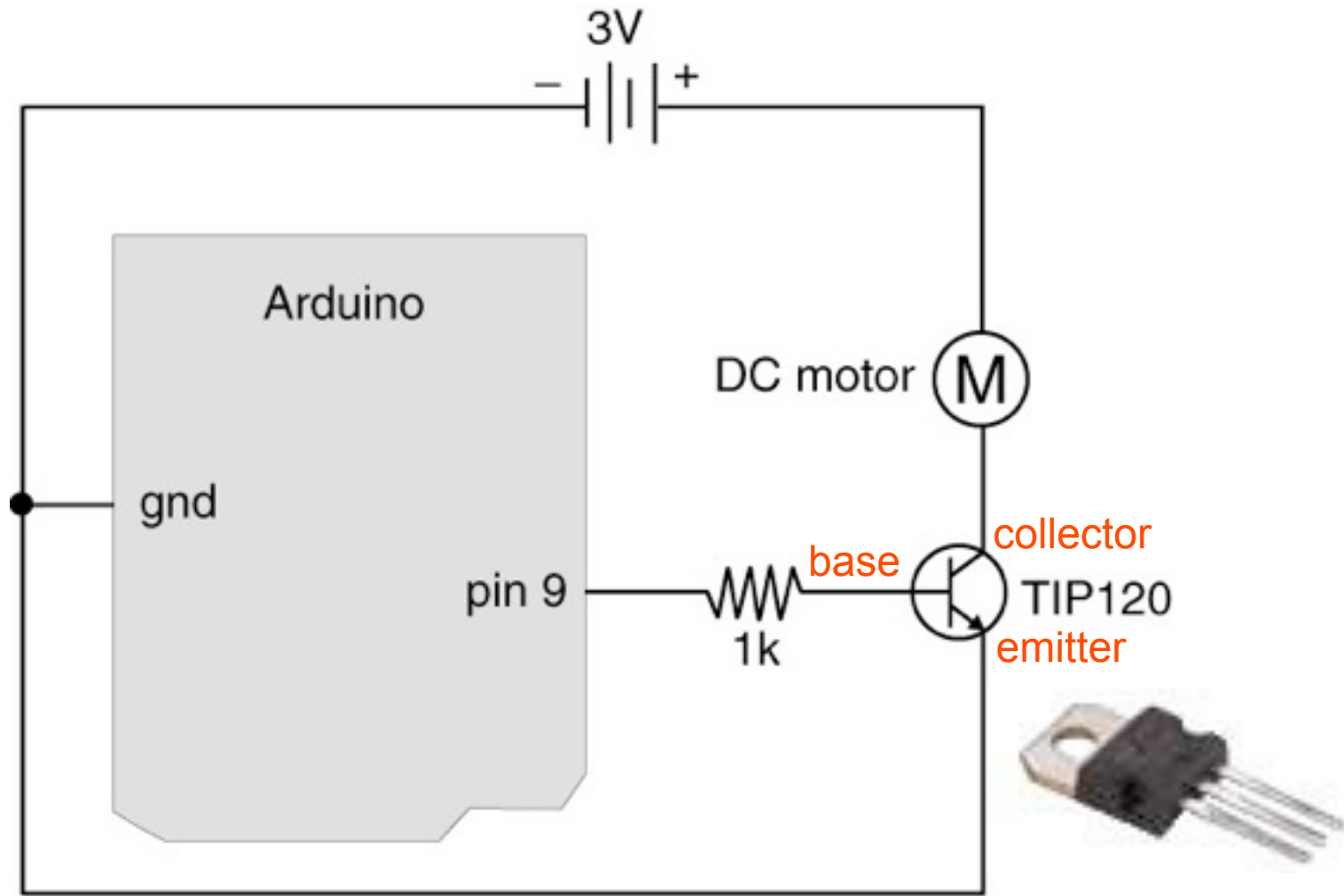

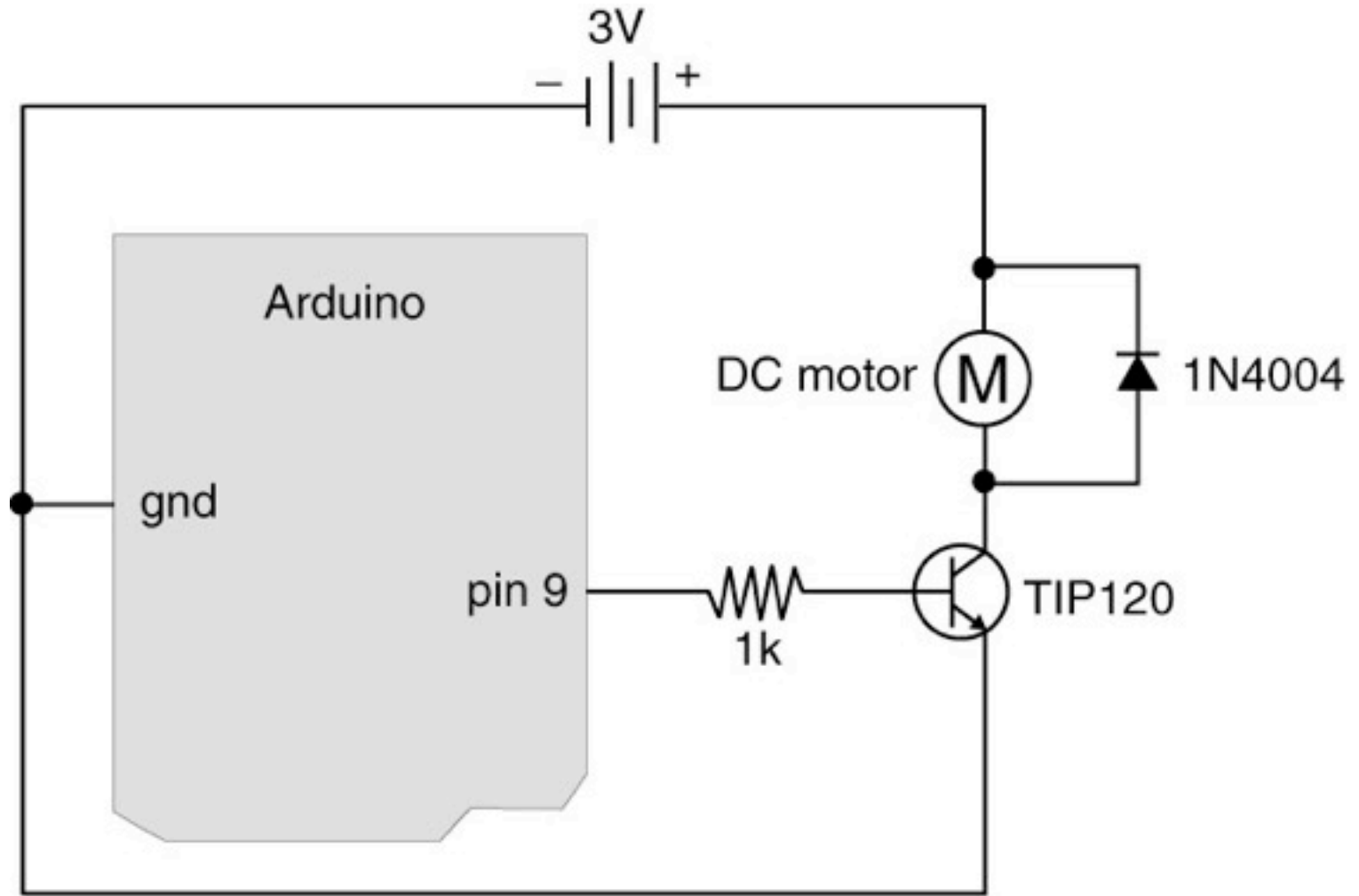

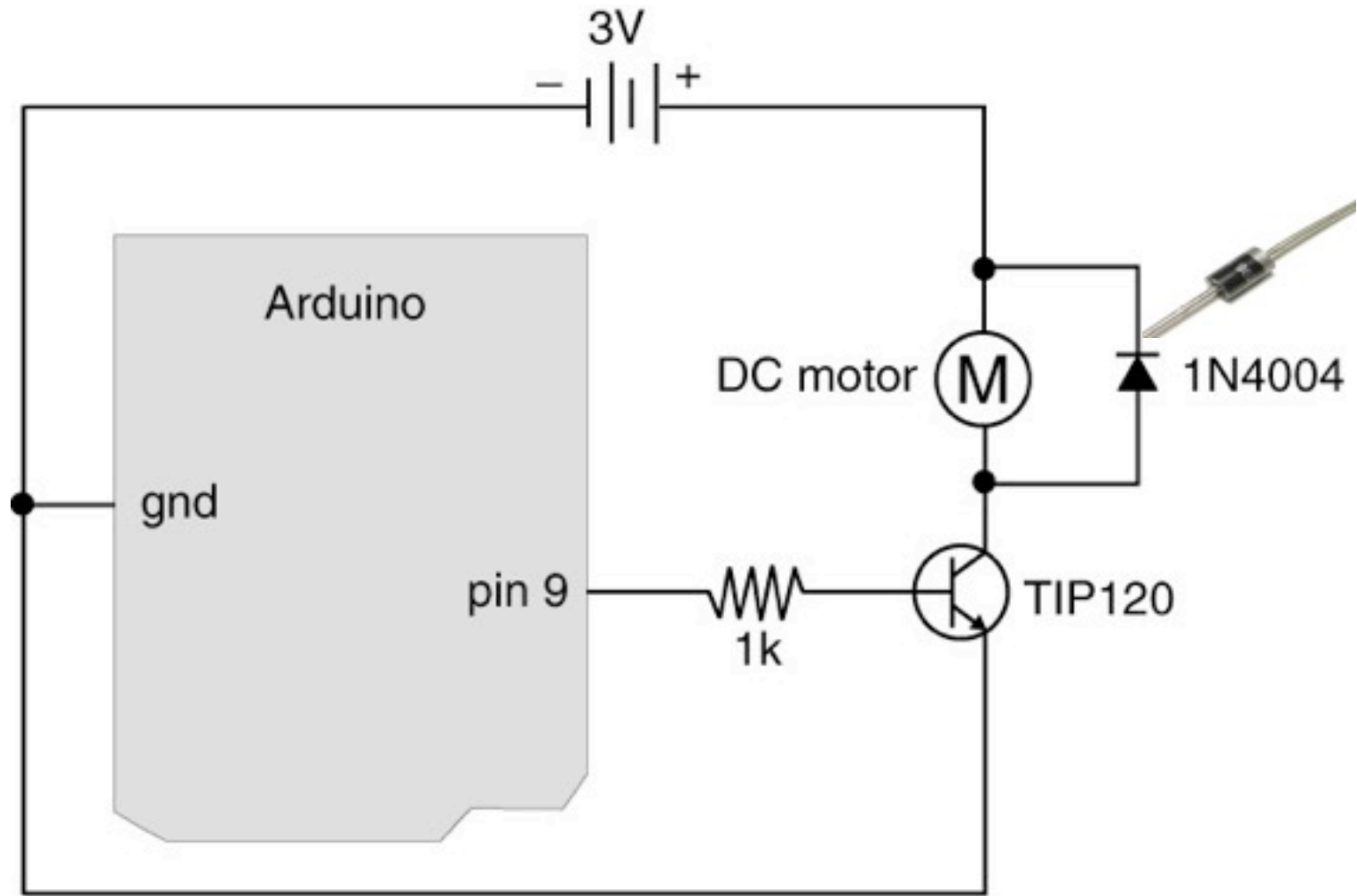

## In Class Exercise

- 1. Solder wires to the motor**
2. Build the DC motor circuit
3. Try your input sensors
4. Explore different propellers and eccentric weights

# DC Motor

---

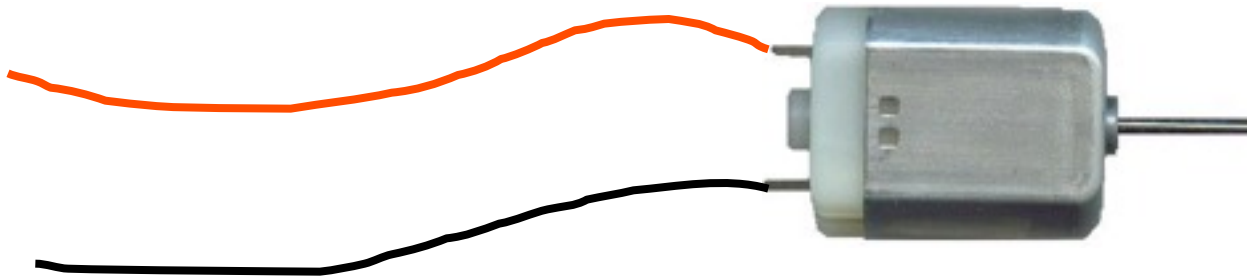

## In Class Exercise

1. Solder wires to the motor
- 2. Build the DC motor circuit**
3. Try your input sensors
4. Explore different propellers and eccentric weights

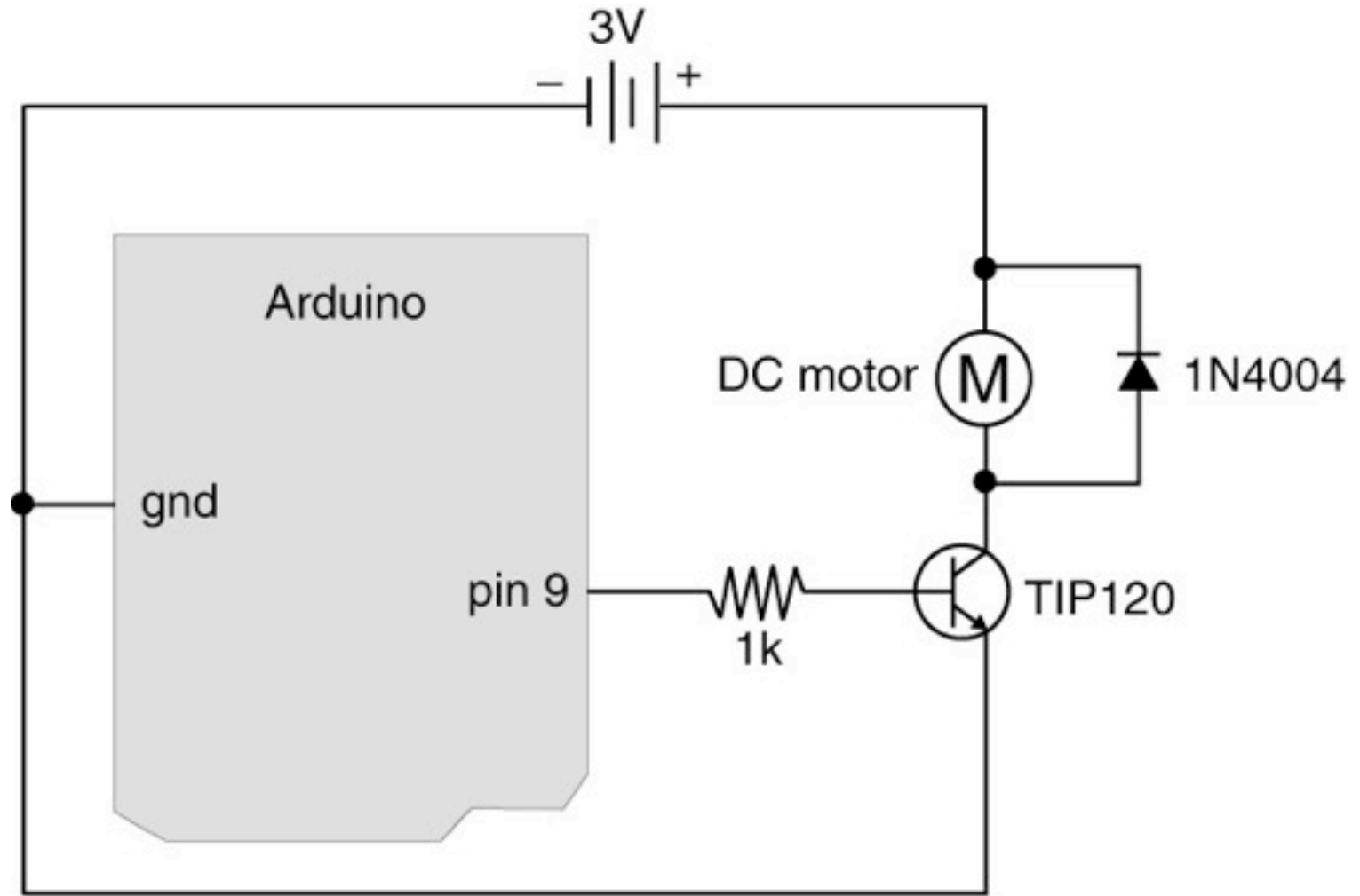

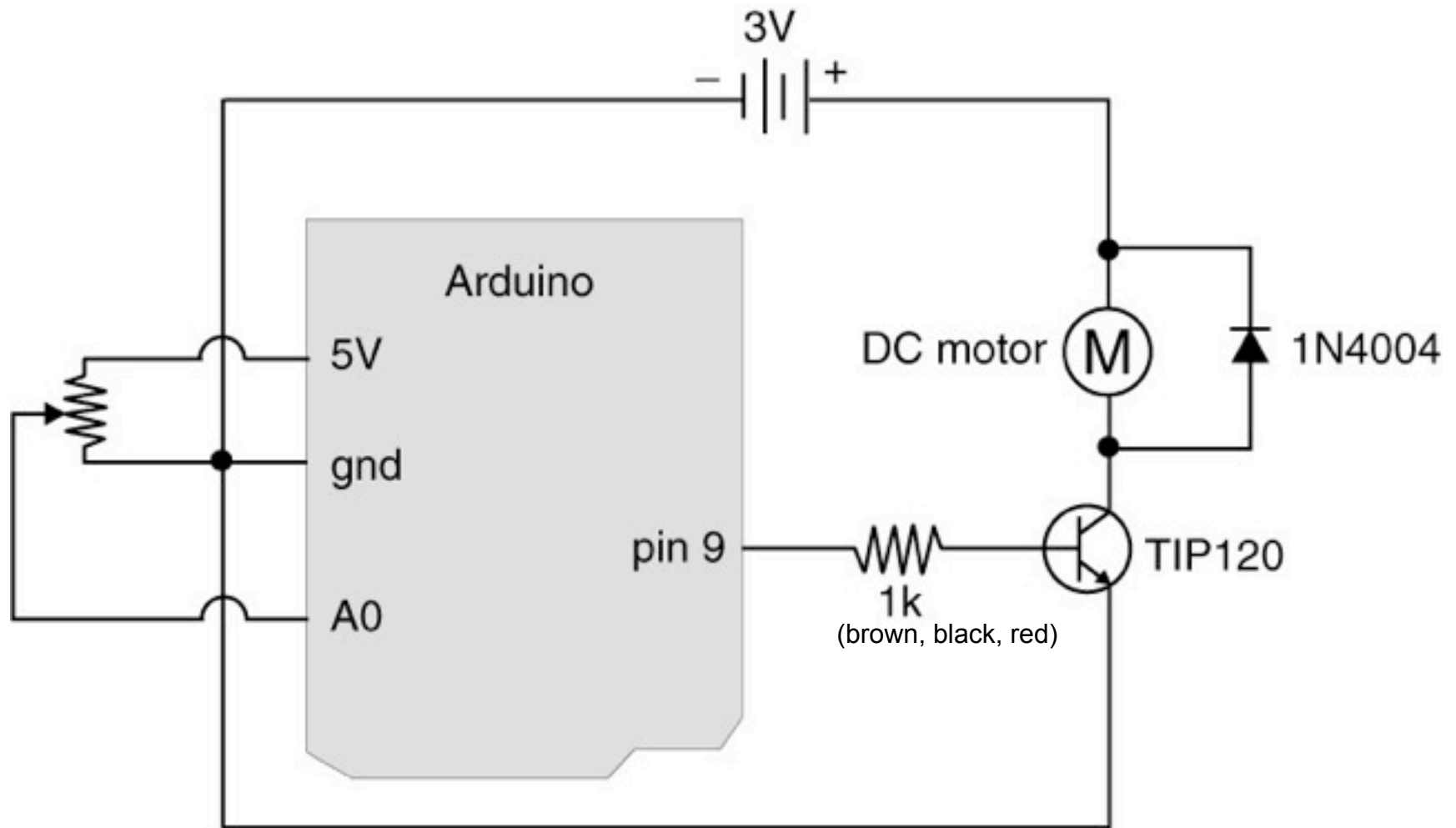



## In Class Exercise

1. Solder wires to the motor
2. Build the DC motor circuit
- 3. Try your input sensors**
4. Explore different propellers and eccentric weights

# PotControlsMotor

```

PotControlsMotor
/*
 * one pot fades one led
 * modified version of AnalogInput
 * by DojoDave <http://www.0j0.org>
 * http://www.arduino.cc/en/Tutorial/AnalogInput
 */
int potPin = 0; // select the input pin for the potentiometer
int ledPin = 9; // select the pin for the LED
int val = 0; // variable to store the value coming from the pot
void setup() {
  Serial.begin(9600);
}
void loop() {
  val = analogRead(potPin); // read the value from the sensor
  Serial.println(val);
  analogWrite(ledPin, val/4); // analogWrite can be between 0-255
}
    
```

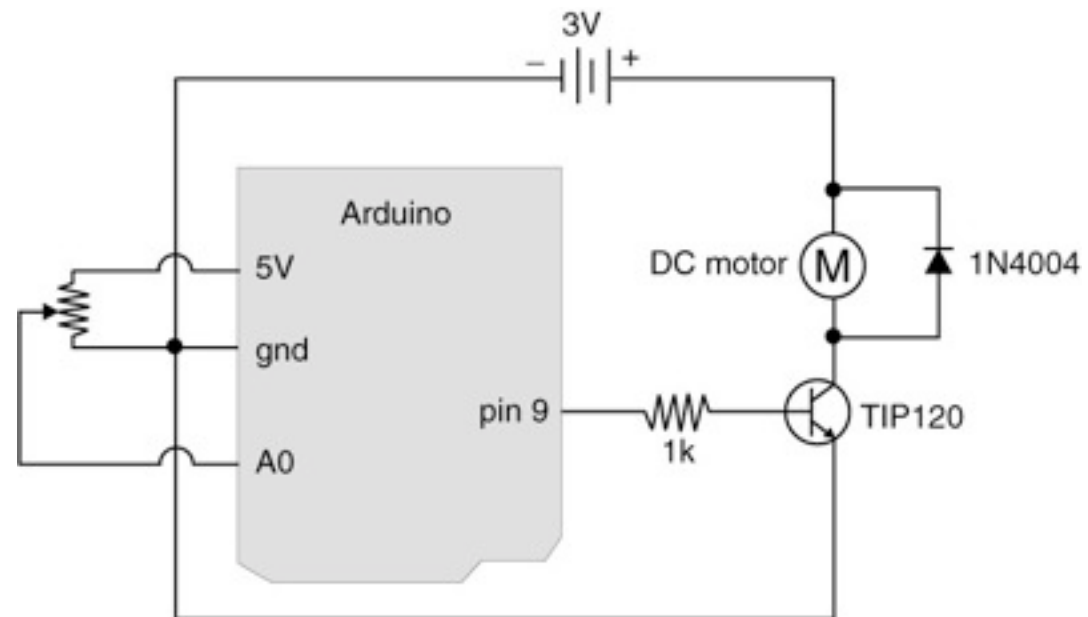

## In Class Exercise

1. Solder wires to the motor
2. Build the DC motor circuit
3. Try your input sensors
- 4. Explore different propellers and eccentric weights**

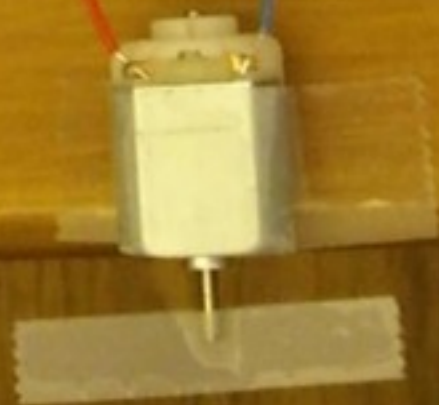
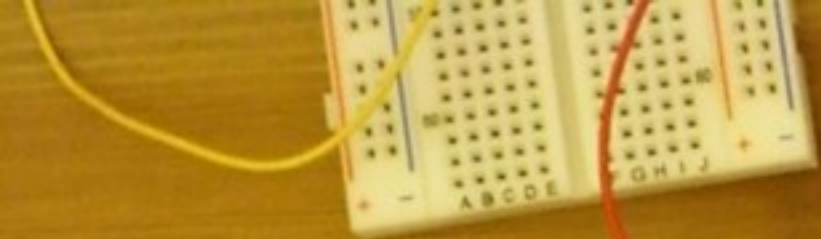

# Cork Eccentric Weight



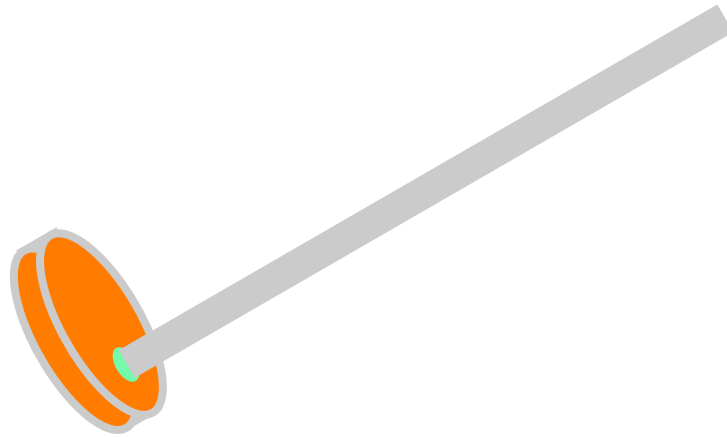

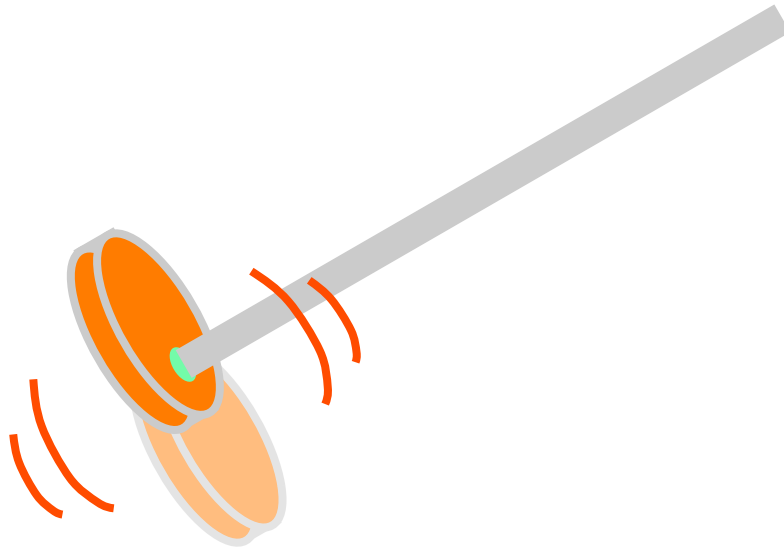

# Eccentric Weight

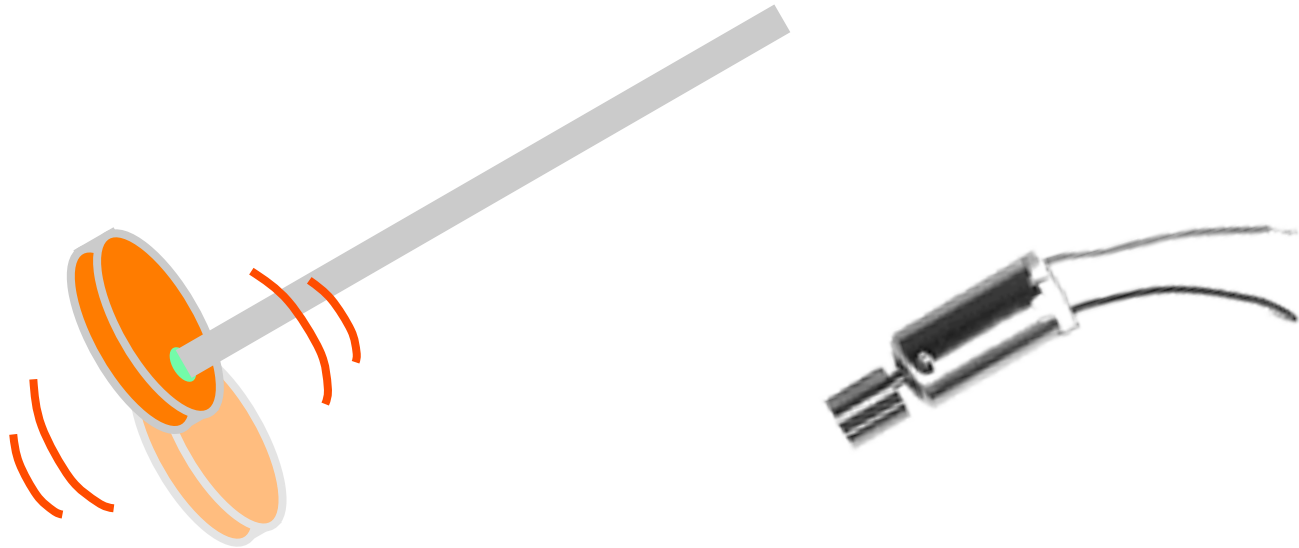



# Cork Eccentric Weight



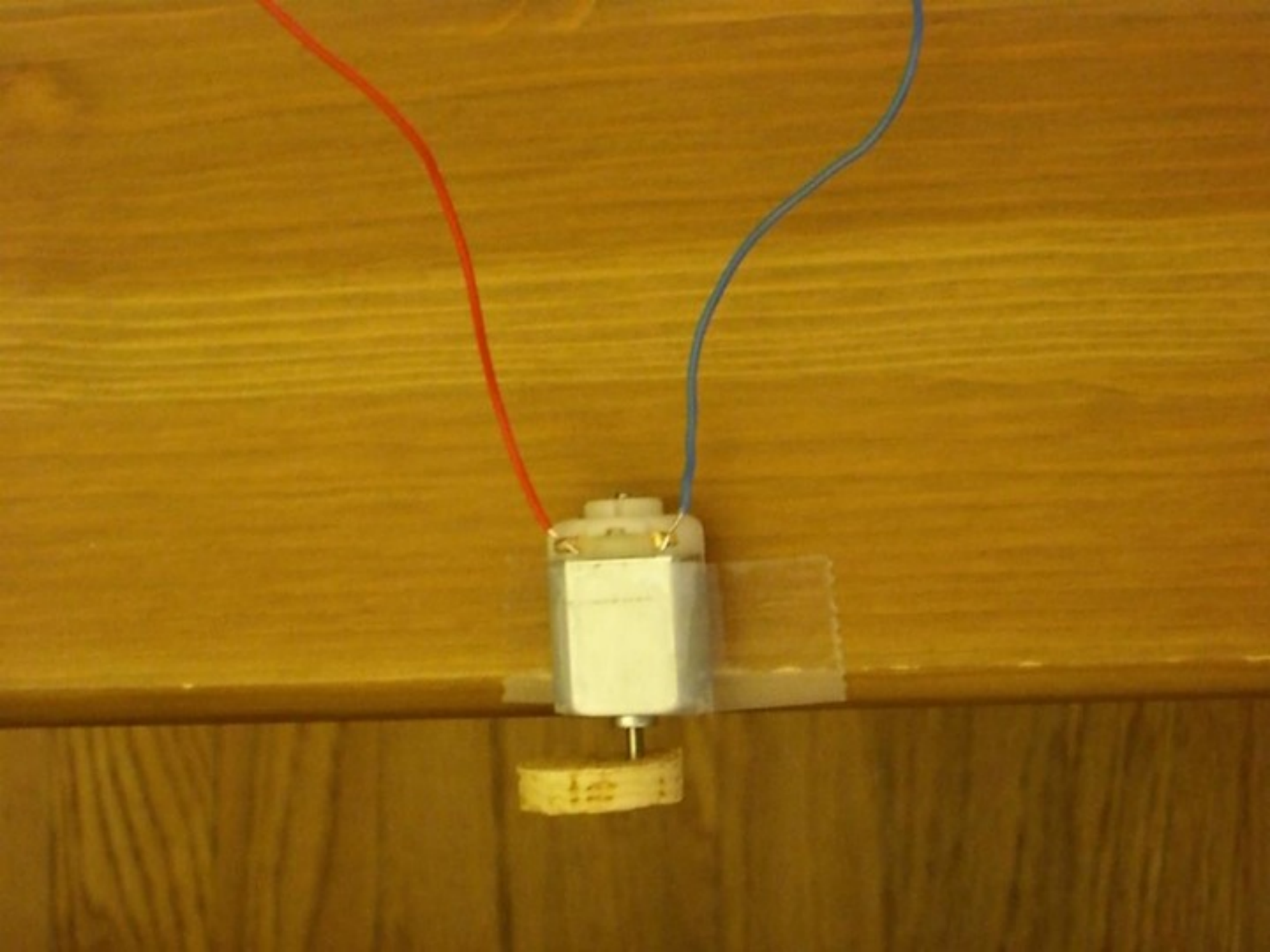

# Supplement Reading

---

Making Movement: Chapter 10 of O'Sullivan and Igoe.

# Assignment this week

---

Explore motion as an output (in a form of display or tactile feedback). Use your DC motor to create vibration or rotational motion (e.g., pinwheels, dancing wires, etc.).

Optional: Combine it with other output (sound, lights, etc.)

# Thanks!